

---

---

**Furniture — Functional sizes and  
performance requirements**

**Part 1: Chairs and tables for office  
furniture**

ICS 97.140

---

---

Reference number

DRS 423-1: 2025

© RSB 2025

In order to match with technological development and to keep continuous progress in industries, standards are subject to periodic review. Users shall ascertain that they are in possession of the latest edition

© RSB 2025

All rights reserved. Unless otherwise specified, no part of this publication may be reproduced or utilized in any form or by any means, electronic or mechanical, including photocopying and microfilm, without prior written permission from RSB.

Requests for permission to reproduce this document should be addressed to:

Rwanda Standards Board

P.O Box 7099 Kigali-Rwanda

KK 15 Rd, 49

Tel. +250 788303492

Toll Free: 3250

E-mail: [info@rsb.gov.rw](mailto:info@rsb.gov.rw)

Website: [www.rsb.gov.rw](http://www.rsb.gov.rw)

ePortal: [www.portal.rsb.gov.rw](http://www.portal.rsb.gov.rw)

**Contents**

Page

Foreword .....	iv
1 Scope .....	1
2 Normative references .....	1
3 Terms and definitions .....	1
4 Types of office chairs and tables .....	2
4.1 Types of chairs .....	2
4.1.1 Type 1 chair .....	2
4.1.2 Type 2 chair .....	2
4.1.3 Type 3 chair .....	2
4.2 Types of tables/desks .....	2
4.2.1 Work table/desk Type 1 .....	2
4.2.2 Work table/desk Type 2 .....	2
4.2.3 Work table/desk Type 3 .....	3
4.2.4 Work table/desk Type 4 .....	3
5 Dimensions for office chairs and tables .....	3
5.1 Dimensions for office chairs .....	3
5.2 Dimensions for office tables .....	5
6 Test methods .....	11
6.1 Determination of dimensions .....	11
6.2 Test methods for strength and durability of office furniture chairs and tables .....	11

## Foreword

Rwanda Standards are prepared by Technical Committees and approved by Rwanda Standards Board (RSB) Board of Directors in accordance with the procedures of RSB, in compliance with Annex 3 of the WTO/TBT agreement on the preparation, adoption and application of standards.

The main task of technical committees is to prepare national standards. Final Draft Rwanda Standards adopted by Technical committees are ratified by members of RSB Board of Directors for publication and gazettment as Rwanda Standards.

RS 423-1 was prepared by Technical Committee RSB/TC 54, *Timber, furniture and engineered wood*.

In the preparation of this standard, reference was made to the following standard:

- 1) ISO 21887- 2007-11, *Durability of wood and wood - based products — Use classes*
- 2) GS 983: 2009, *Furniture — Specification for Furniture Components*

The assistance derived from the above source is hereby acknowledged with thanks.

RS 423 consists of the following parts, under the general title *Furniture — Functional sizes and performance requirements*:

- *Part 1: Chairs and tables for office furniture*
- *Part 2: Storage units*
- *Part 3: Chairs and tables for educational institutions*
- *Part 4: Chairs and tables for home furniture*

This second edition cancels and replaces the first edition (RS 423-1: 2020), [clauses 2, 3, 5 and 6] which have been technically revised.

## Committee membership

The following organizations were represented on the Technical Committee on *Timber, Furniture and Engineered wood* (RSB/TC 54) in the preparation of this standard.

CAMOSAG LTD

Cleaner Production and Climate Innovation Centre (CPCIC)

Energy Development Corporation Limited (EDCL)

GIZ

National Industrial Research and Development Agency (NIRDA)

Rwanda Inspectorate, Competition and Consumer Protection Authority (RICA)

Rwanda Transport development Agency (RTDA)

Ultimate Forest Company Ltd

University of Rwanda – College of Science and Technology (UR-CST)

Rwanda Standards Board (RSB) – Secretariat

Copy for public review only

## Introduction

Despite the Rwandan growth trend, the wood sector has not been implemented as required to produce high quality wood products and vigorous competitive market. The quality of wooden furniture is highly affected by the quality of timber, standardized production chain, quality control mechanism and grading rules. The lack of aforesaid factors results into market dominated by poor quality wooden furniture, compromised safety and unfair competition at the market.

The emerging market dynamics show that consumer's preferences have gradually shifted from furniture made by local timbers to the imported ones, which is considered as a limiting factor to the development and growth of the wood economy in Rwanda.

To ensure a positive trade balance in wood market there is a dire need to improve and ensure quality of domestic wood products.

This Standard is one of the series of standards on furniture in Rwanda. The series currently consists of the following:

RS 413: 2020, *Furniture — Quality and grading of wooden furniture*

RS 423-2: 2020, *Furniture — Functional sizes and Performance Requirements — Part 2: Storage units*

RS 423-3: 2020, *Furniture — Functional sizes and Performance Requirements — Part 3: Chairs and tables for educational institutions*

RS 424: 2020, *Furniture — Bedsteads — Specification*

RS 427: 2020, *Round and sawn timber — Nomenclature of timbers used in Rwanda*

DRS 433: 2019, *Furniture — Chairs and tables for home furniture — Functional sizes, strength, durability and stability for seating and tables (Under development)*

DRS 434: 2019, *Furniture — Tables — Test methods for the determination of stability, strength and durability (Under development)*

DRS 435: 2019, *Timber in joinery — General requirements (Under development)*

RS ISO 7173:1989, *Furniture — Chairs and stools — Determination of strength and durability.*

# Furniture — Functional sizes and performance requirements — Part 1: Chairs and tables for office furniture

## 1 Scope

This Draft Rwanda Standard specifies the basic functional sizes for office chairs and tables. It specifies methods for the determination of the dimension of office chairs and tables.

It includes requirements for strength and durability.

It does not cover requirements for:

- a) materials, design, construction or quality; and
- b) stability.

## 2 Normative references

The following documents are referred to in the text in such a way that some or all of their content constitutes requirements of this document. For dated references, only the edition cited applies. For undated references, the latest edition of the referenced document (including any amendments) applies.

RS ISO 24496, *Office furniture — Office chairs — Methods for the determination of dimensions*

RS ISO 21015, *Office furniture — Office work chairs — Test methods for the determination of stability, strength and durability*

RS ISO 19682:2023, *Furniture — Tables — Test methods for the determination of stability, strength and durability*

RS 423-2, *Furniture — Functional sizes and Performance Requirements — Part 2: Storage units*

RS 423-3, *Furniture — Functional sizes and Performance Requirements — Part 3: Chairs and tables for educational institutions*

## 3 Terms and definitions

For the purposes of this standard, the terms and definitions in RS 423-2, RS 423-3, RS ISO 13007 and the following apply.

### 3.1

#### **armrest**

part of a chair that supports the arm

### 3.2

#### **adjustable**

ability for the user to change the functions of the chair without the need of any tool

### 3.3

#### **office chair**

piece of seating furniture for one person, with a backrest, with or without armrests and with or without headrest used for seating in an office environment

Note 1 to entry The upper part of the chair, which includes the seat, can rotate in the horizontal plane and can be adjusted in height. Office chair fall into three types; type 1, type 2 and type 3.

## **4 Types of office chairs and tables**

### **4.1 Types of chairs**

#### **4.1.1 Type 1 chair**

Adjustable work chair with large range of adjustment.

#### **4.1.2 Type 2 chair**

Adjustable work chair, some features may be fixed.

#### **4.1.3 Type 3 chair**

Work chair with limited adjustability.

### **4.2 Types of tables/desks**

#### **4.2.1 Work table/desk Type 1**

Work table/desk with height adjustable; the height can be changed by the user during use.

#### **4.2.2 Work table/desk Type 2**

Work table/desk with height selectable; the height can be adapted to the user at installation.



### 4.2.3 Work table/desk Type 3

Work table/desk with fixed height.

### 4.2.4 Work table/desk Type 4

Work table/desk with limited height selectable or adjustable.

## 5 Dimensions for office chairs and tables

### 5.1 Dimensions for office chairs

5.1.1 In the case of Figure 1, the legroom shall be rectangular with dimensions as specified in Table 3.

5.1.2 In the case Figure 2, the legroom shall be curved with dimensions as specified in Table 3.

NOTE 1 Figure 1 shows the legroom for all work surfaces which have straight front edges at least all along the width, W, see Table 3.

NOTE 2 Figure 2 shows the legroom for all work surfaces with non-straight front edges.

5.1.3 The dimensions descriptions for office chairs are given in RS ISO 24496, as listed in Table 1:

**Table 1 — Definition of dimensions according to RS ISO 24496**

S/N	Dimension description	RS ISO 24496, clause reference
1.	angle between backrest and se	3.1
2.	armrest height	3.2
3.	armrest length	3.3
4.	distance between armrests	3.4
5.	front of armrest position	3.5
6.	armrest width	3.6
7.	backrest to seat movement ratio	3.7
8.	backrest angle to vertical	3.8
9.	backrest width	3.9
10.	backrest height	3.10
11.	backrest inclination range	3.11
12.	horizontal backrest radius	3.12
13.	chair measuring device, CMD	3.13
14.	hip breadth clearance	3.14
15.	lumbar support height	3.15

16.	lumbar support protrusion, Lumbar support height Adjustable height of lumbar support / Fixed height of lumbar support	3.16
17.	lumbar zone	3.17
18.	median plane	3.18
19.	neck/head rest protrusion	3.19
20.	neck/head rest height	3.20
21.	seat depth, distance from the backrest line measured parallel to the CMD buttocks pad to the front of the seat	3.21
22.	seat height, vertical distance, measured at the front of the seat, from the loaded seat to the floor	3.22
23.	sitting height	3.23
24.	Seat inclination Seat pad angle adjustable / Seat pad angle fixed minimum	3.24
25.	seat surface depth	3.25
26.	seat surface width	3.26
27.	seat surface width zone	3.27
28.	maximum off-set of the underframe	3.28

**Table 2 — Dimensions of an office chair (Dimensions in millimetres)**

S/N	Dimension	Type 1 chair		Type 2 chair		Type 3 chair	
		Min.	Max.	Min.	Max.	Min.	Max.
1.	Seat height	400	520	420	510	430	480
2.	Adjustable depth of the seat	425	475	425	445	425	-
3.	Fixed depth of the seat	Type 1 chair shall be adjustable		425	485	425	-
4.	Adjustable height of lumbar support	200	300	180	300	190	-
5.	Fixed height of lumbar support	Type 1 chair shall be adjustable		180	300	180	-
6.	Maximum distance from the backrest to the front of the armrests		250		300	-	300
7.	Angle between seat and back	90	-	90	-	90	-
8.	Seat pad angle adjustable	-7	3	-7	-2	-7	-2
9.	Seat pad angle fixed	Type 1 chair shall be adjustable		-5	3	-5	3
10.	Hip breadth clearance when armrest are in widest position	480	-	460	-	460	-

11.	Adjustable clear distance between armrest pads	360	510	460	510	460	-
12.	Fixed clear distance between armrest pads	Type 1 chair shall be adjustable		460	510	460	250
13.	Height of armrests adjustable	200	290	225	250	200	-
14.	Height of armrests not adjustable	Type 1 chair shall be adjustable		225	275	200	-
15.	Seat pad width	400	-	400	-	400	-
16.	Seat pad depth	425	-	425	-	400	-
17.	Backrest height	360	-	360	-	360	-
18.	Backrest width	360	-	360	-	360	-
19.	Radius of backrest	400	-	400	-	400	-
20.	Height of adjustable neck rest or head rest	550	740	590	-	590	-
21.	Height of fixed neck rest or head rest	Type 1 chair shall be adjustable		590	-	590	-
22.	Armrest length	150	-	150	-	150	-
23.	Armrest width	50	-	40	-	40	-
24.	Offset of the underframe	-	415	-	415	-	415

## 5.2 Dimensions for office tables

Office tables shall meet dimensions specified in Table 3.

**Table 3 — Dimensions for office tables (Dimensions in millimeters)**

Dimensions		Work table/desk type					
		Type 1	Type 2	Type 3	Type 4		
		Fully adjustable	Fully selectable	Fixed height	Limited adjustable or limited selectable <sup>e</sup>		
h1	Height of the work surface	Sitting only	Minimum range 650 - 850	Minimum range 650 - 850 <sup>a</sup>	740 ± 20	Min	Max
					680	760	
	Standing only	Minimum range 950 - 1 250	Minimum range 950 - 1 250 <sup>a</sup>	1 050 ± 20	Min	Max	
					1000	1 180	
	Sit/stand	Minimum range 650 - 1 250	N/a	N/a	Minimum range 680 - 1 180		

t1 and t2	Maximum desk top thickness see figure 1	At the front, t1	55 <sup>b</sup>	55 <sup>b</sup>	70	70
		At 500 mm from the front edge, t2	80 <sup>b</sup>	90 <sup>b</sup>	100	100
k1 (See Figure 3)	Minimum height of knee clearance for standing position only	Applies only to tables with a height more than 850 mm	700 <sup>d</sup>	700 <sup>d</sup>	700 <sup>d</sup>	700 <sup>d</sup>
k2	Minimum depth of knee clearance for standing position only		80	80	80	80
k3 (see figure 3)	Minimum depth of foot clearance for standing position only		150	150	150	150
f1 and f2	Minimum height of minimum foot clearance	Sitting only and sit/stand From 600 mm to 800 mm from the front edge, f1	120	120	120	120
		Standing only From front edge to 150 mm, f2	120	120	120	120
g1	Minimum legroom depth c	Sitting only and sit/stand	800	800	800 <sup>f</sup>	800
D	Minimum desk top depth <sup>g</sup>		800	800	800 <sup>f</sup>	800
W	Minimum legroom width	Sitting only and sit/stand	1 200	1 000	850	850
		Standing only	790	790	790	790

- a Maximum increment of 20 mm
- b Only applies to sitting and sit/stand work tables/desks
- c The construction of the product shall ensure the minimum legroom depth
- d Measured from the floor
- e The minimum and maximum values shall be obtained
- f 600 mm can in some situations be acceptable, e.g. when 17" or smaller flat screens are used, providing that the work surface is not against the wall and that two people are not sitting one in front of each other. Information about these limitations shall be provided with the product
- g The dimension D is measured as the smallest dimension at the work area

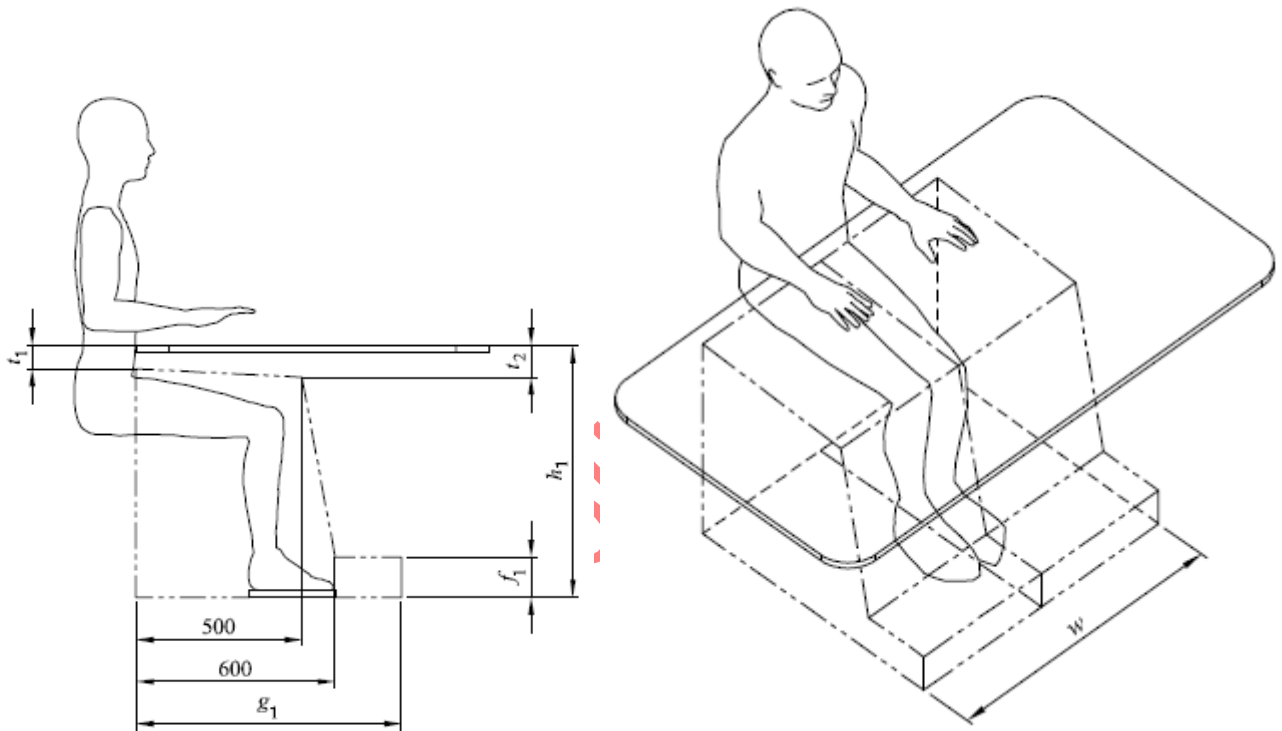

Copy to

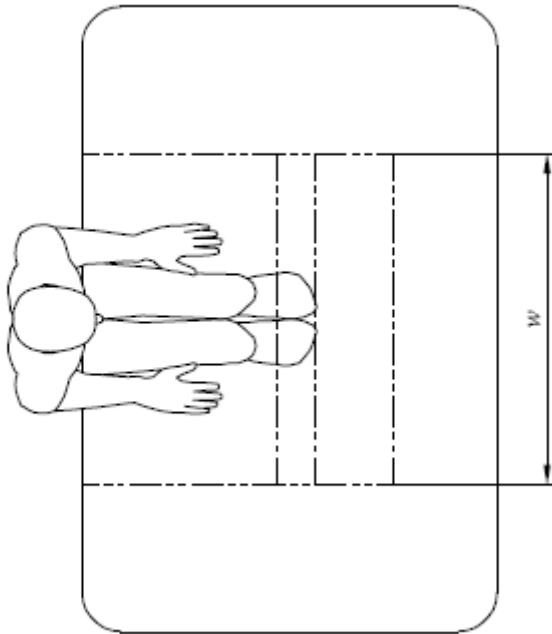

**Key**

- h<sub>1</sub> height to the top of the work surface
- t<sub>1</sub> maximum desk top thickness at the front
- t<sub>2</sub> maximum desk top thickness at 500 mm from the front edge
- f<sub>1</sub> height of foot clearance
- g<sub>1</sub> minimum legroom depth
- w minimum legroom width

**Figure 1 — Legroom and height for work tables/desks with straight front edges**

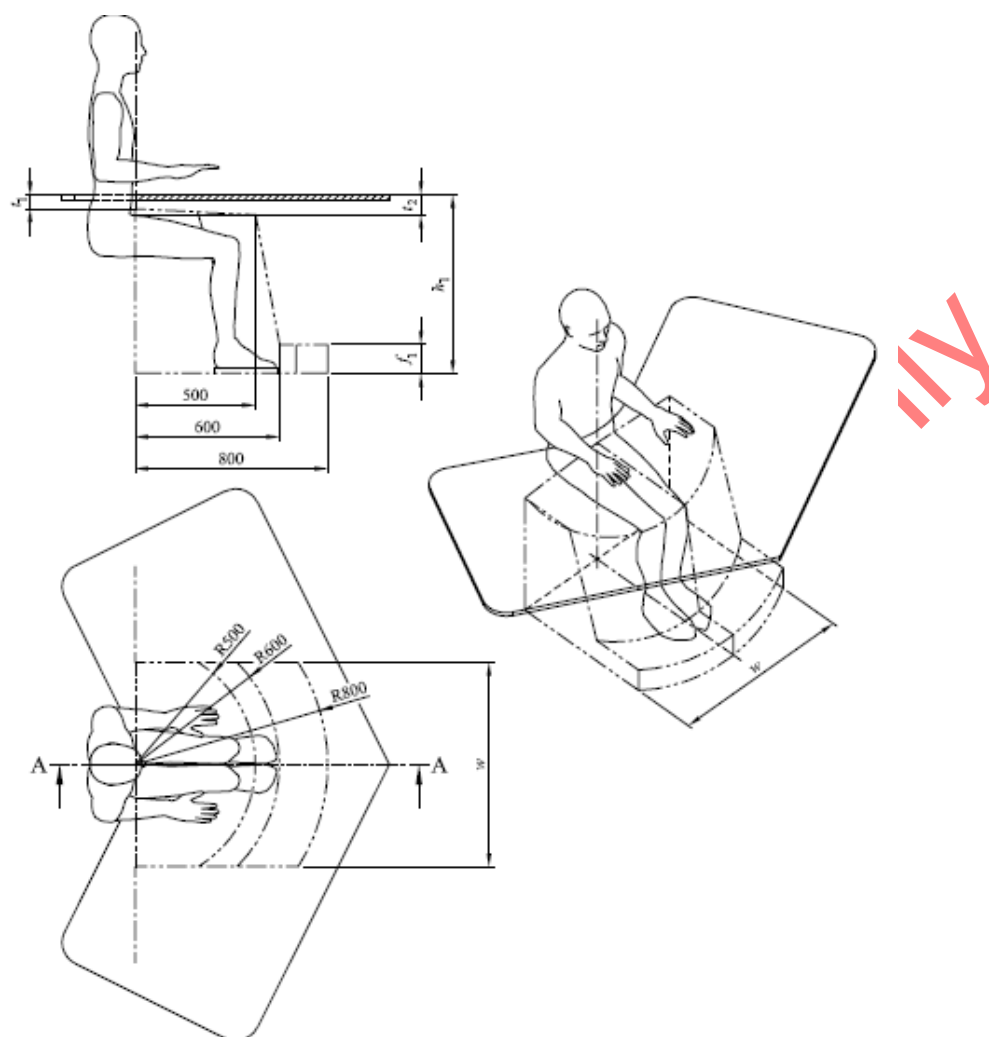

**Key**

- $h_1$  height to the top of the work surface
- $t_1$  maximum desk top thickness at the front
- $t_2$  maximum desk top thickness at 500 mm from the front edge
- $f_1$  height of foot clearance
- $g_1$  minimum legroom dept
- $w$  minimum legroom width

Figure 2 — Legroom and height for work tables/desks with non-straight front edges

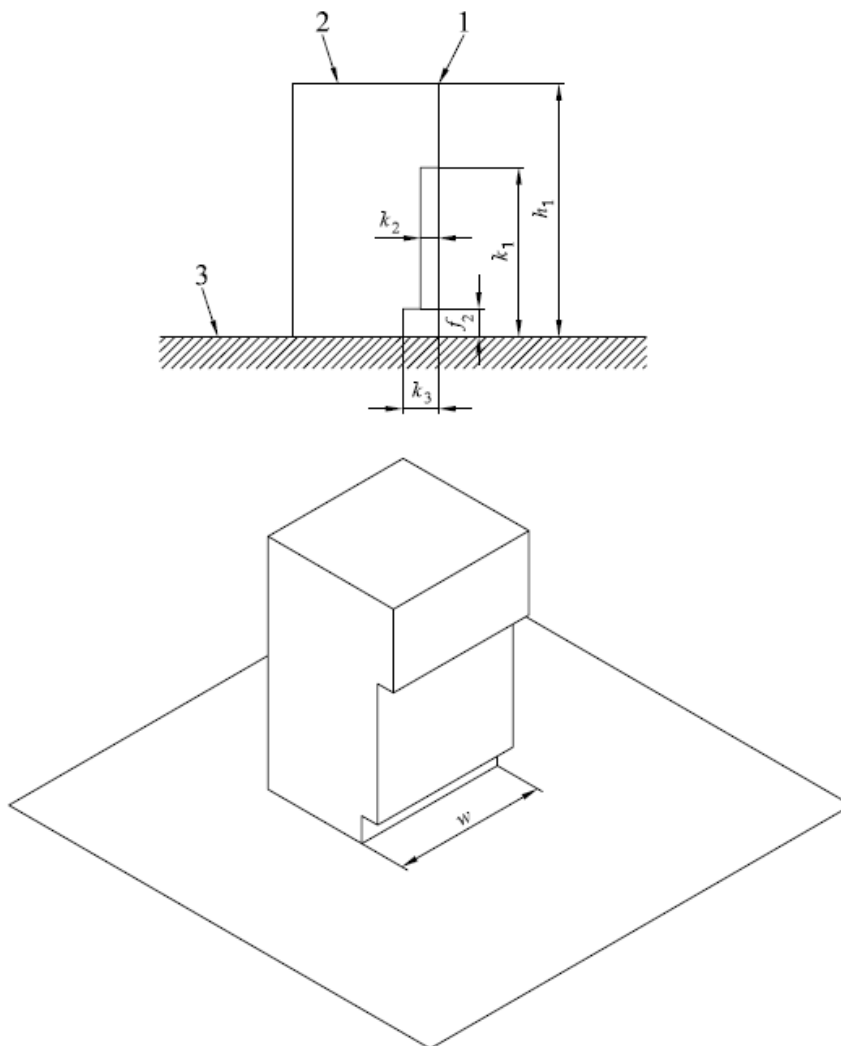

**Key**

- 1 front edge
- 2 top of the work surface
- 3 floor
- $h_1$  height to the top of the work surface
- $k_1$  height of knee clearance
- $k_2$  depth of knee clearance



- $k_3$  depth of foot clearance
- $f_2$  height of foot clearance
- $w$  minimum legroom width

**Figure 3 — Foot and knee clearance dimensions for standing position only**

## **6 Test methods**

### **6.1 Determination of dimensions**

**6.1.1** Position the work table/desk on a flat horizontal and rigid floor surface, with levelling device(s) fully closed. Inclinable desk top work surfaces shall be set to the horizontal or as near to the horizontal as possible. Before commencing measurement procedure, it shall be determined whether the table/desk is for sitting, standing or sit/stand use.

**6.1.2** The minimum and maximum height of work surface shall be measured at the front edge (see Figure 1) and the adjustment range shall be recorded. For height selectable work tables/desks Type 2 and Type 4 the minimum height increments shall also be recorded.

**6.1.3** The legroom depth shall be measured at the working position and with the rear edge of the work table/desk placed against a vertical wall.

### **6.2 Test methods for strength and durability of office furniture chairs and tables**

**6.2.1** Strength and durability tests for office furniture chair shall be performed in accordance with RS ISO 21015.

**6.2.2** Strength and durability tests for office furniture tables shall be performed in accordance with RS ISO 19682:2023.

## Bibliography

- [1] IS 4415: 1974, *Glossary of terms relating to wooden furniture and fixture*
- [2] Furniture testing 101, *The Definitive Guide to North American Furniture Testing*. Source: <http://www.intertek.com/furniture>
- [3] IS 3663: 1991, *Dimensions of chairs and tables for office purposes*
- [4] EN 527-1:2011-08, *Office furniture – Work tables and desks – Part 1: Dimensions*

Copy for public review only

Copy for public review only

---

---

Price based on 11 pages

©RSB 2025 - All rights reserved