



**RWANDA
STANDARD**

**DRS
516**

First edition

2022-mm-dd

**Natural stone — Rough blocks —
Requirements**

ICS 73.020, 91.100.15

Reference number

DRS 516: 2022

© RSB 2022

In order to match with technological development and to keep continuous progress in industries, standards are subject to periodic review. Users shall ascertain that they are in possession of the latest edition

© RSB 2022

All rights reserved. Unless otherwise specified, no part of this publication may be reproduced or utilized in any form or by any means, electronic or mechanical, including photocopying and microfilm, without prior written permission from RSB.

Requests for permission to reproduce this document should be addressed to:

Rwanda Standards Board

P.O Box 7099 Kigali-Rwanda

KK 15 Rd, 49

Tel. +250 788303492

Toll Free: 3250

E-mail: info@rsb.gov.rw

Website: www.rsb.gov.rw

ePortal: www.portal.rsb.gov.rw

Contents

Page

Foreword	V
1 Scope	1
2 Normative references	1
3 Terms and definitions	1
4 Requirements	4
4.1 Requirements for geometric characteristics	4
4.1.1 Measurement criteria	4
4.1.2 Shape	4
4.1.3 Volume	4
4.1.4 Mass	4
4.2 Requirements for natural stone for rough blocks	4
4.2.1 General	4
4.2.2 Denomination	5
4.2.3 Visual appearance	5
4.2.4 Apparent density and open porosity	5
4.2.5 Flexural strength	5
4.2.6 Other requirements	5
5 Marking	6
6 Evaluation of conformity and factory production control	6
6.1 Evaluation of conformity	6
6.2 Initial type testing	6
6.3 Factory production control	7
Annex A (normative) Sampling	9
A.1 General	9
A.2 Principles of sampling	9
A.3 Taking bulk samples	9
A.4 Preparing a sampling plan	9
A.5 Sampling apparatus	10
A.6 Sampling methods	10
A.6.1 General	10
A.6.2 Sampling from quarries	10
A.6.3 Sampling from plants	11
A.6.4 Sampling from buildings	11
A.7 Marking, packaging and dispatch of the samples	11
A.8 Sampling report	12
Annex B (normative) Determination of flexural strength under concentrated load	14
B.1 Scope	14
B.2 Principle	14
B.3 Symbols	14
B.4 Apparatus	14
B.5 Preparation of specimens	15
B.5.1 Sampling	15
B.5.2 Test specimens	15
B.6 Test procedure	16
B.7 Expression of results	16
B.8 Test report	17

Copy for public comments

Foreword

Rwanda Standards are prepared by Technical Committees and approved by Rwanda Standards Board (RSB) Board of Directors in accordance with the procedures of RSB, in compliance with Annex 3 of the WTO/TBT agreement on the preparation, adoption and application of standards.

The main task of technical committees is to prepare national standards. Final Draft Rwanda Standards adopted by Technical committees are ratified by members of RSB Board of Directors for publication and gazettment as Rwanda Standards.

DRS 516 was prepared by Technical Committee RSB/TC 9, *Civil engineering and building materials*.

In the preparation of this standard, reference was made to the following standard:

EN 1467: 2012, *Natural stone - Rough blocks - Requirements*

The assistance derived from the above source is hereby acknowledged with thanks.

Committee membership

The following organizations were represented on the Technical Committee on *Civil engineering and building materials* (RSB/TC 9) in the preparation of this standard.

A + Construction Group Ltd

Africeramics Ltd

Consultants Engineers Group (CEG) Ltd

D&D Resources Ltd

Dutureheza Ltd

Enabel Rwanda

Greenpack Africa Ltd

Integrated Polytechnic Regional Centre (IPRC) - Musanze

Mass Design Group

NP Construction Construction Company (NPCC) Ltd

Road Transport Development Agency (RTDA)

DRS 516: 2022

Rwanda Housing Authority (RHA)

Rwanda Inspectorate, Competition and Consumer Protection Authority (RICA)

Rwanda Quarries Association (RQA)

SKAT Consult

St Joseph Engineering Company (SJEC) Ltd

Standards for Sustainability (SfS)

Stonecraft Industries Ltd

University of Rwanda - College of Science and Technology (UR - CST)

Rwanda Standards Board (RSB) – Secretariat

Copy for public comments

Natural stone — Rough blocks — Requirements

1 Scope

This Draft Rwanda Standard specifies requirements for rough blocks of natural stone from which products for use in building or commemorative stones and other similar applications are made.

It does neither cover artificially agglomerated stony material nor installation.

2 Normative references

The following referenced documents are indispensable for the application of this document. For dated references, only the edition cited applies. For undated references, the latest edition of the referenced document (including any amendments) applies.

DRS 526, Natural stone test methods — Determination of real density and apparent density, and of total and open porosity

DRS 515, Natural stone — Terminology and Classification

DRS 517, Natural stone masonry units — Specification

DRS 527, Natural stone test methods — Petrographic examination

DRS 528, Natural stone — Denomination criteria

DRS 535, Natural stone test methods — Determination of flexural strength under constant moment

DRS 530, Natural stone test methods — Determination of geometric characteristics on units

3 Terms and definitions

For the purposes of this document, the terms and definitions given in DRS 515 and the following apply.

3.1

commercial size of a rough block

size which is obtained by reducing each net dimension by 0.05 m (see Figure 1)

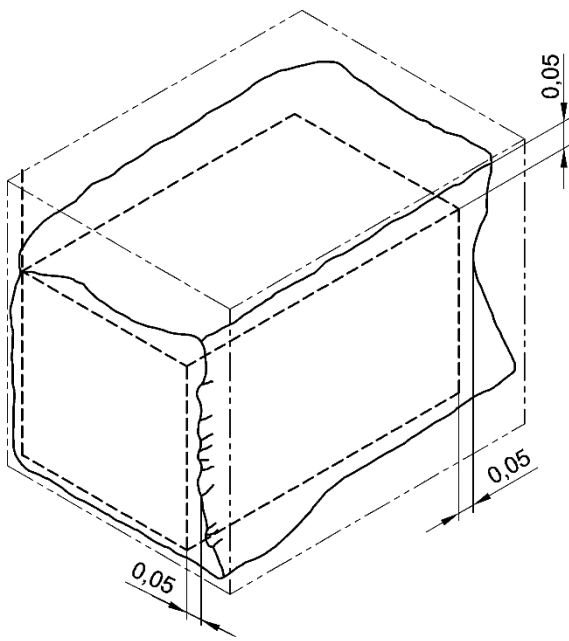

where

----- gross size

----- commercial size

Figure 1 — Gross sizes, commercial sizes of a rough block

3.2

dimensions of a rough block

length l , width b and height h are the dimensions of a squared rough block. They are given in the stated sequence in meters to two decimals places

3.2.1

length l

greater side in a natural layer where appropriate

3.2.2

width b

smaller side in the natural layer or at right angles to length

3.2.3

height h

side at right angles to the natural layer (see Figure 2) or to the plane containing length l and width b

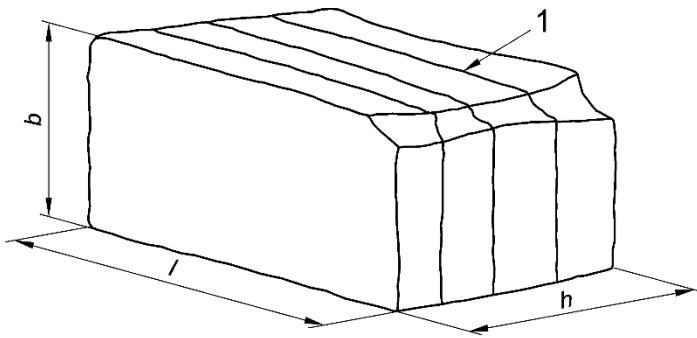

where,

1 natural layer

Figure 2 — Dimensions of a rough block

3.3

gross size of the rough block

size defined by the lengths of the edges of the smallest parallelepiped circumscribed to a rough block (see Figure 1)

3.4

net size of a rough block

size which is determined in the following manner: Establish the greatest inscribed parallelepiped block which shall not contain any sides without right angles nor contain drill holes and other holes. The resulting figure is the net size.

3.5

rough block

basis of the usable stone consisting of rocks obtained directly from quarries or erratics with no processing whatsoever except extraction and shaping by cutting or splitting

3.6

rough block of specific size

squared rough block with certain given dimensions

3.7

shapeless rough block

rough block without regular shape and size

3.8

squared rough block

rough block which corresponds approximately to a regular parallelepiped

Note 1 to entry: Normally the ratio obtainable by dividing the mass of the squared rough block by the apparent density should be bigger than 80 % of the gross size. If such a ratio is equal to or less than 80 %, the block is considered a shapeless rough block.

4 Requirements

4.1 Requirements for geometric characteristics

4.1.1 Measurement criteria

All measurements shall be carried out in accordance with DRS 530 and indicated in metres to two decimals places.

4.1.2 Shape

The six sides of squared rough block shall be approximately flat, right-angled and parallel, and correspond to the shape of a parallelepiped. Local deviations from the parallelepiped shape are permitted.

Shapeless rough blocks for commercial purposes are only measured by mass, (see 4.1.4); gross size shall be provided upon request.

Rough blocks of specific size shall have dimensions not lower than the minimum values and not greater than the maximum values agreed between the purchaser and the supplier.

4.1.3 Volume

The volume of a rough block shall be stated in cubic metres to three decimals places. The volume may be calculated by dividing the mass of the block by the apparent density.

4.1.4 Mass

The mass of a rough block shall be stated in tonnes with three decimals. The mass shall be obtained by weighing; for squared blocks the approximate mass may be obtained by multiplying the volume by the apparent density.

4.2 Requirements for natural stone for rough blocks

4.2.1 General

The following characteristics shall be declared where requested by this standard, or with reference to use conditions:

- a) the declared values shall be representative of the current production. However, due to natural variations of the stone materials, deviations from the declared values may occur. Expected deviations shall be indicated by the manufacturer; and
- b) in case of layered stone: If a rough block contains different types of stones (see 4.2.2), all characteristics shall be declared.

4.2.2 Denomination

The denomination (traditional name, petrological family, typical colour and place of origin) shall always be declared in accordance with DRS 528.

NOTE The place of origin can be given by GPS coordinates.

The petrologic definition shall be determined in accordance with DRS 527.

4.2.3 Visual appearance

4.2.3.1 This characteristic shall be declared upon request.

4.2.3.2 The colour, veining, texture, etc. of the stone shall be identified visually (for example by a polished reference sample). The reference sample shall be provided by the supplier.

4.2.3.3 Any visual variations, for example inclusions and veins, are permissible, provided that they are characteristic of the relevant type of natural stone and provided that they do not adversely affect the performances of the stone products

4.2.4 Apparent density and open porosity

4.2.4.1 This characteristic shall always be declared.

4.2.4.2 The apparent density and open porosity shall be determined in accordance DRS 526 and the mean value, lower expected value and standard deviation shall be declared.

4.2.5 Flexural strength

4.2.5.1 This characteristic shall always be declared.

4.2.5.2 The flexural strength shall be tested in accordance with Annex B. The mean value, lower expected value and standard deviation shall be declared.

4.2.6 Other requirements

Where required, for example, when the derived product is to be used for a specific purpose, additional tests may be requested in accordance with relevant product standard.

5 Marking

5.1 As a minimum of identification, each consignment shall carry the following indications:

- a) the denomination of the natural stone, in accordance with DRS 528;
- b) the mass and the volume of each block; and
- c) the dimensions (including at least gross and commercial sizes) of each block.

5.2 The direction of the natural layer of each block shall be clearly marked where appropriate. Each block shall be clearly identified by a recorded identification system.

6 Evaluation of conformity and factory production control

6.1 Evaluation of conformity

6.1.1 Compliance with the requirements of this Draft Rwanda Standard and with the stated values or classes of reaction to fire shall be demonstrated by carrying out initial type testing. Additionally, the manufacturer shall exercise a permanent factory production control (FPC) and keep record of the results for at least 3 years.

6.1.2 The declared values shall be representative of the current production, for example, the lowest expected value or the minimum test value in normal production.

6.1.3 For sampling, see Annex A.

6.1.4 When the rough blocks manufacturer declares conformity with some characteristics included in a product standard, the evaluation of conformity of the block shall include initial type testing and factory production control as described in the appropriate product standard.

6.2 Initial type testing

Initial type testing of a natural stone rough block shall be carried out as given in Table 1.

- a) on the first application of this Rwanda Standard or at the beginning of production of a new type of stone;
- b) when significant variations occur in the material that are determined visually or by significant changes in FPC results.

Tests previously performed in accordance with the provisions of this Rwanda Standard (same type of stone, same characteristic measured with same test method, same sampling procedure and system of attestation of conformity) may be taken into account.

The results of the selected tests shall be expressed as referred to in 4.2.

Table 1 — List of properties of rough blocks for initial type testing

Reference to subclauses for applicability ^a	Properties/Characteristics	Test method in accordance with
4.2.2	Denomination	DRS 527 & DRS 528
4.2.3	Visual appearance	Visual
4.2.4	Apparent density and open porosity	DRS 526
4.2.5	Flexural strength	DRS 517, Annex B

^a Reference shall be made to these sub clauses in order to decide which tests need to be declared.

6.3 Factory production control

6.3.1 A factory production control system (FPC) shall be established and documented. The factory production control system shall consist of procedures for the internal control of production. The results of the tests carried out during FPC shall demonstrate that products placed on the market conform to this Rwanda Standard and with the manufacturer's declared values in accordance with 4.1 and 4.2.

6.3.2 In cases when the processing of the stone is likely to change the characteristics of the finished product relative to the initial material (e.g. in consequence of the type of processing or because the use of patching, fillers or other similar products for natural holes, faults, cracks and similar), then this shall be considered within the FPC, as requested by this Rwanda Standard.

6.3.3 The internal control shall consist of regular inspection checks and tests, and the utilisation of the results to control materials, equipment, the production process and the rough blocks.

6.3.4 The tests and inspection checks shall be in accordance with Table 2, when tested in accordance with test methods specified therein.

Table 2 — Control frequency of factory production control

Reference to subclauses for applicability ^a	Characteristics	Control frequency	Test method
4.1	Geometric characteristics	Every production lot ^b	DRS 530
4.2.3	Visual appearance		Visual
4.2.4	Apparent density and open porosity	In accordance with FPC system but at least every 2 years	DRS 526.
4.2.5	Flexural strength		DRS 517, Annex B

^a Reference shall be made to these subclauses in order to decide which tests need to be declared.

^b The dimension or amount of a production lot shall be determined by the manufacturer, having as reference the daily production quantity and the number of deliveries of the considered quantity of slabs.

6.3.5 The results of the tests carried out during FPC shall demonstrate conformity to the requirements declared in 4.1 and 4.2.

6.3.6 Manufacturers' records shall include at least the following:

- a) identification of the product tested;
- b) information on sampling (see Annex A):
 - 1) place and date of sampling;
 - 2) identification of the production lot sampled;
 - 3) frequencies of sampling; and
 - 4) size and number of samples;
- c) the test methods applied;
- d) the results of the tests carried out; and
- e) calibration records of apparatus.

Copy for public comments

Annex A (normative)

Sampling

A.1 General

This annex specifies methods for obtaining samples of natural stone from quarries, plants or buildings. Sampling from buildings may be necessary if the delivered natural stone product has already been applied in a building.

The aim of sampling is to obtain a bulk sample that is representative of the average properties of the batch and of its variabilities.

The methods described are based on manual procedures, and are limited to building and civil engineering purposes.

It is important that samplers are trained accordingly in the application of the methods set out in this document. In the case of a dispute, or if tests are to be done by more than one organization, all interested parties shall have the opportunity to observe the sampling and shall agree upon the number of sampling increments to be taken.

A.2 Principles of sampling

Proper and careful sampling and sample transport is a prerequisite for an analysis that will give reliable results. An adequate number of samples have to be taken in order to obtain a good estimation of the natural heterogeneity of the batch.

The sampler shall be informed of the aim of the sampling.

A.3 Taking bulk samples

The number and size of samples depend on the test methods for which they are taken. The number and shape of specimens are given in the relevant test methods.

A.4 Preparing a sampling plan

Sampling plan shall be prepared prior to sampling, taking into account the following:

- a) the type of the natural stone;
- b) the aim of the sampling including a list of the properties to be tested;
- c) the identification of sampling points;

- d) the approximate size of samples;
- e) the number of samples;
- f) the sampling apparatus to be used;
- g) the methods of sampling; and
- h) the marking, packaging and dispatch of the samples.

A.5 Sampling apparatus

Any suitable cutting equipment for natural stone may be used for sampling. In addition, drills, which are suitable for taking drill cores, may be used.

A.6 Sampling methods

A.6.1 General

The sampling methods will inevitably involve the samplers working at a quarry, plant or building. Regulations for safety and ergonomics shall be followed.

A.6.2 Sampling from quarries

A.6.2.1 General

The sample shall be taken by qualified personnel, experienced in the examination of natural stone deposits. The main objective of sampling from such deposits is to establish the average, the range of variations and the differences in the structure and properties of the natural stone, taking into account the fabric, geological structure and the anticipated quarrying conditions.

A.6.2.2 Sampling of solid rock

- a) Identification of anisotropy and orientation of samples

If the exploratory work reveals a pronounced fabric or geological structure which is not necessarily visible at the sample scale (e.g. stratification, massive bedding, lamination, cleavage or rift), the sample shall be marked accordingly.

- b) Sampling for petrographic analysis

For petrographic analysis, hand specimens shall be taken from all distinct types and varieties that characterize the rock in terms of mineral composition, fabric and geological structure.

Samples from drilling (cores and pieces) may also be used.

In addition to samples of fresh material, samples shall also be taken to illustrate the effects of weathering. c) Sampling for physical testing

For physical testing, sample blocks shall be used as samples, their number and location dependent on the results of the petrographic analysis and the required test methods.

The sample blocks shall measure approximately 0.40 m x 0,25 m x 0.25 m or more where a coarse-grained and/or a large-pored rock is to be sampled

It is recommended that samples be taken from larger natural stones which have been the least affected by blastings. Care has to be applied to ensure the sample blocks do not show any hairline cracks resulting from the removal process.

Samples may also be cut from rough blocks, slabs or dimension stones, the number and size of samples dependent on the particular test method.

A.6.3 Sampling from plants

A representative sample of adequate size and characteristic of the natural stone in terms of mineral composition, fabric and geological structure, shall be taken from the material to be tested (e. g. slabs, dimension stones), taking into account the intended use of the material.

A.6.4 Sampling from buildings

Sampling points shall be selected according to the rules for obtaining a representative sample, taking into consideration any differences in properties visible to the naked eye. Where necessary, taking a single slab to assess the mechanical properties in situ will be sufficient.

The location of the sample in the building shall be reported.

A.7 Marking, packaging and dispatch of the samples

A.7.1 The samples or containers shall be clearly and durably marked. Marking shall include:

- a) a unique code; or
- b) identification of the laboratory samples, including place of sampling, date of sampling and DRS 528ination of the material.

A.7.2 The laboratory samples shall be packed and transported in such a way that they are protected from damage.

A.8 Sampling report

A.8.1 The sampler shall prepare a sampling report for each laboratory sample or for each group of laboratory samples from a single source. The sampling report shall refer to this Rwandan Standard and state the following:

- a) the sampling report identification (serial number);
- b) the laboratory sample identification mark(s);
- c) the date and place of sampling;
- d) sampling point(s) or identification of the batch sampled;
- e) a reference to the sampling plan prepared according to A.4; and
- f) the name of the sampler(s).

A.8.2 Depending on the circumstances, other information might be relevant. Table A.1 shows an example of a comprehensive sampling report.

Table A.1 — Example of a sampling report

Sampling report identification (serial n°):	
Laboratory sample identification mark:	no. of package

Description of the natural stone and sampling places

Name of the quarry or production plant or building:
Name of producer:
Origin of batch:
Purpose for which the natural stone is to be used:
Location of sampling point(s):
Identification of the batch:
Size of the batch:
Other comments (e. g. warnings, if appropriate):

Description of the sampling method

Date and time of sampling:
Reference to sampling plan used:
Sampling procedure (drilling, cutting, etc.):
Purpose of the sampling:

Samples

No. and dimensions of samples:
Other comments:
Dispatch of the samples:
Sampler(s) (print name):

Contract details

Contract identification:
Name and address of party requesting the sampling:.....
Name of person(s) present at sampling:.....
Signatures:.....

Copy for public comments

Annex B (normative)

Determination of flexural strength under concentrated load

B.1 Scope

This annex specifies a test method for determination of flexural strength under a concentrated load for natural stone. Both an identification and a technological product testing procedure are included.

B.2 Principle

The principle of this method is to place a specimen on two rollers and to progressively load the specimen in the middle. The breaking load is measured and the flexural strength calculated.

B.3 Symbols

For the purposes of this document, the following symbols apply.

R_{tf} flexural strength, in Megapascals;

F breaking load, in newtons;

a load rate, in Megapascals/second;

V loading rate, in newtons/second;

l distance between the supporting rollers, in millimetres;

b width of the specimen adjacent to the plane of fracture, in millimetres;

h thickness of the specimen adjacent to the plane of fracture, in millimetres; and

L total length of the specimen, in millimetres.

B.4 Apparatus

- A balance capable of weighing the specimen with an accuracy of 0,01 % of the mass of the specimen.
- A ventilated oven capable of maintaining a temperature of (70 ± 5) °C.
- A linear measuring device with an accuracy of 0,05 mm.
- A testing machine of appropriate force, in accordance with the RS ISO 1920 and calibrated according to this Rwanda Standard.
- A device for applying loads on the specimen by a centre-point load. It consists of two lower rollers (supporting rollers) and one upper roller (load-applying roller) which shall be centred exactly in the

middle between the two supporting rollers (see Figure 1). The distance between the two supporting rollers shall be reported as requested in 6.2.2.

- f) A room which can be maintained at a temperature of (20 ± 10) °C.

B.5 Preparation of specimens

B.5.1 Sampling

The sampling is not the responsibility of the test laboratory except where specially requested. At least 10 specimens shall be selected from a homogeneous batch.

B.5.2 Test specimens

B.5.2.1 Surface finish

As a standard reference, the surface finish of the faces of the specimens shall be sawn, honed or polished (identification test). In case of necessity to test specimens with other surface finishes (e.g. flamed, sandblasted) as required for application, this may be done (technological test). For the technological test the specimens may be final products or sawn from final products. The surface intended for use shall be in contact with the two supporting rollers (facing downwards). In any case the kind of surface finish shall be stated in the report.

B.5.2.2 Dimensions

For stones with a size of the largest grain lower than 25 mm, preferred dimensions are 50 X mm X 50 mm X 300 mm.

Other dimensions are possible, but shall fulfil the following requirements:

- a) the thickness h shall be between 25 mm and 100 mm and shall be greater than twice the size of the largest grain in the stone;
- b) the total length L shall be equal to six times the thickness;
- c) the width b shall be between 50 mm and three times the thickness ($50 \text{ mm} \leq b \leq 3h$), and in no case it shall be less than the thickness; and
- d) the distance between the supporting rollers l shall be equal to five times the thickness.

B.5.2.3 Tolerance

The tolerance on the distance between the supporting rollers l shall be ± 1 mm.

B.5.2.4 Planes of anisotropy

If the stone shows planes of anisotropy (e.g. bedding, foliation) the specimens shall be prepared in accordance with at least one of the arrangements shown in Figures 2 to 4 and the direction of the planes of anisotropy shall be marked on each specimen by at least two parallel lines.

If the use of the stone in respect of the position of the planes of anisotropy is known, the test shall be carried out with the force applied on the face that will be loaded during use.

B.5.2.5 Conditions before testing

The specimens shall be dried at (70 ± 5) °C to a constant mass.

Constant mass is reached when the difference between two weighings carried out (24 ± 2) h apart is not greater than 0.1 % of the first of the two masses.

After drying and prior to testing the specimens shall be stored at (20 ± 5) °C until the thermal equilibrium is reached. After that the test shall be performed within 24 h.

B.6 Test procedure

Wipe the surface of the rollers clean and remove any loose grits from the faces of the specimen that will be in contact with the rollers.

The specimen is placed centrally on the supporting rollers (see Figures 1 to 4). The loading roller is placed in the middle of the specimen.

The load is increased uniformly at a rate of (0.25 ± 0.05) MPa/s until the specimen breaks.

NOTE 1 The breaking load is rounded to the nearest 10 N and also the place where the fracture occurs. The width and the thickness of the specimen are measured adjacent to the fracture plane and the dimensions are expressed in millimetres to the nearest 0,1 mm.

NOTE 2 Where the loading rate (V) is needed in N/s the following equation can be used to determine the required rate in N/s:

$$V = \frac{2abh^2}{3l} \text{ (N/s)} \quad (1)$$

B.7 Expression of results

The flexural strength R_{ff} of each specimen is calculated using the following equation:

$$R_{ff} = \frac{3Fl}{2bh^2} \quad (2)$$

The result shall be expressed in Megapascals to the nearest 0.1 MPa.

If the fracture is situated more than 15 % of the distance between the supporting rollers from the middle of the specimen and/or flaws are present (veins, fissures etc.), it shall be mentioned in the test report.

B.8 Test report

B.8.1 The test report shall contain the following information:

- a) unique identification number of the report;
- b) the number, title and date of issue of this Rwanda Standard,
- c) the name and address of the test laboratory and the address where the test was carried out if different from the test laboratory;
- d) the name and address of the client;
- e) it is the responsibility of the client to supply the following information:
 - 1) the petrographic name of the stone;
 - 2) the commercial name of the stone;
 - 3) the country and region of extraction;
 - 4) the name of the supplier;
 - 5) the direction of any existing plane of anisotropy (if relevant to the test) to be clearly indicated on the sample or on each specimen by means of two parallel lines;
 - 6) the name of the person or organization which carried out the sampling; and
 - 7) the surface finish of the specimens (if relevant to the test);
- f) the date of delivery of the sample or of the specimens;
- g) the date when the specimens were prepared (if relevant) and the date of testing;
- h) the number of specimens in the sample;
- i) the dimensions of the specimens;
- j) the surface finish of the specimens;
- k) the rate of loading in Megapascals per second to the nearest 0.05 MPa/s;
- l) for each specimen: the width and thickness adjacent to the fracture plane and the distance between the supporting rollers in millimetres to the nearest 0.1 mm, the orientation of the force relatively to any plane of anisotropy following Figures 2 to 4, the breaking force in newton to the nearest 10 N, the flexural strength in Megapascals to the nearest 0.1 MPa, the location of the fracture and any anomalies observed;
- m) for each relevant direction of loading the mean value R_{tf} of the flexural strength and the standard deviations, in Megapascals to the nearest 0.1 MPa;

- n) all deviations from the standard and their justification; and
- o) remarks.

B.8.2 The test report shall contain the signature(s) and the role(s) of the responsible(s) for the testing and the date of issue of the report. It shall also state that the report shall not be partially reproduced without written consent of the test laboratory.

nts

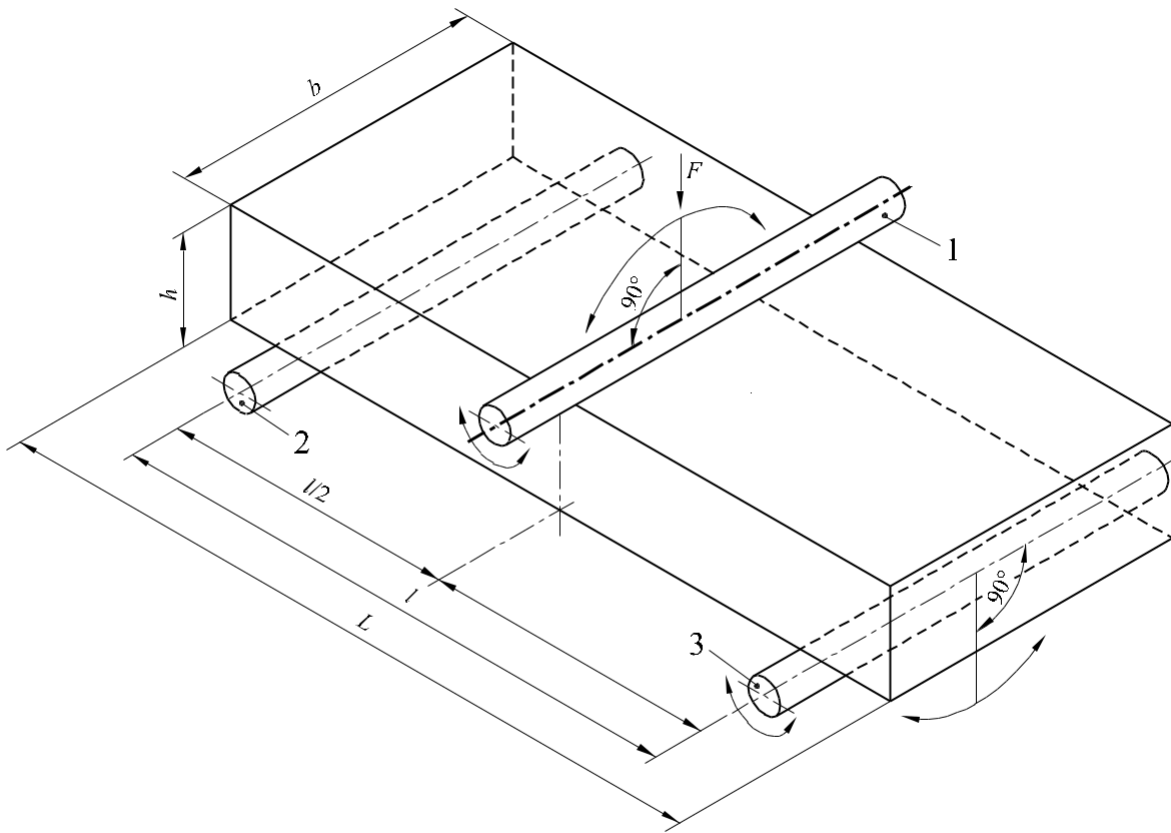

- Key**
- 1 loading roller
 - 2 supporting roller

Figure B.1 — Arrangement of loading of test specimen (centre point loading)

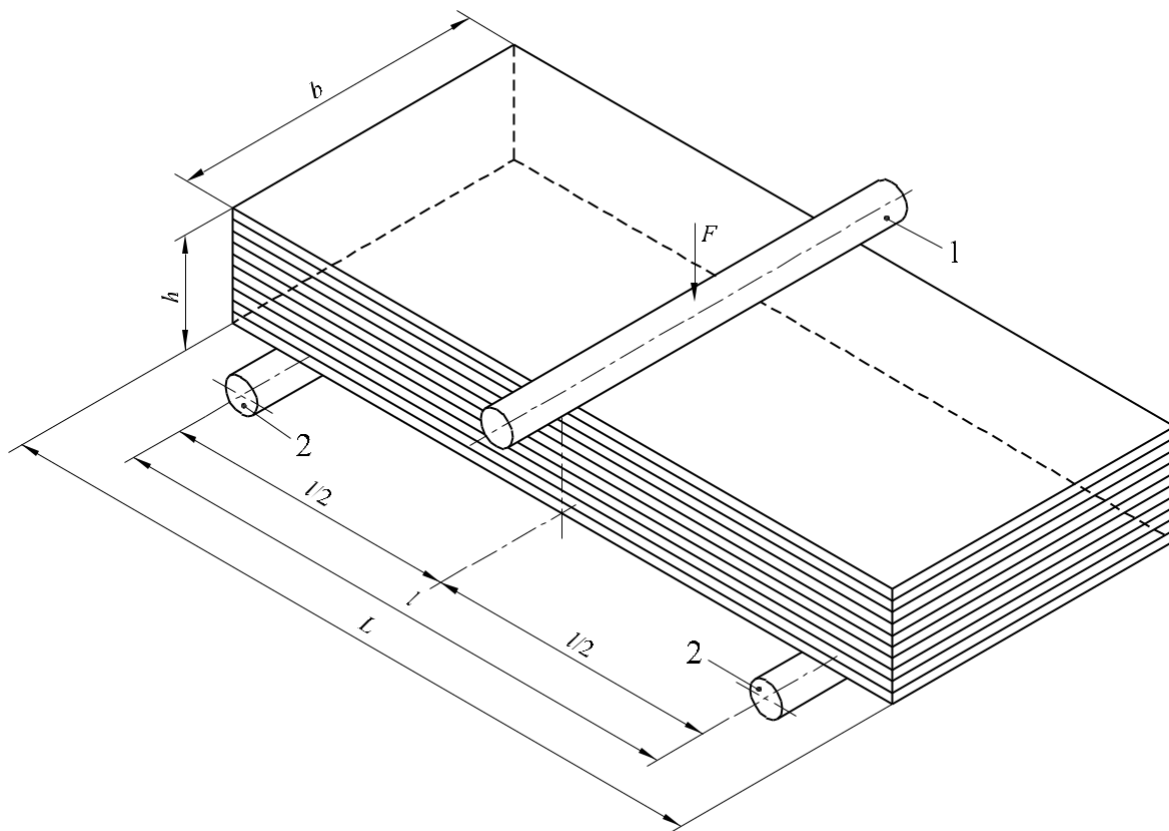
**Key**

- 1 loading roller
- 2 supporting roller

Figure B.2 — Test arrangement for a specimen with the load applied perpendicular to the planes of anisotropy

Copy for Publi

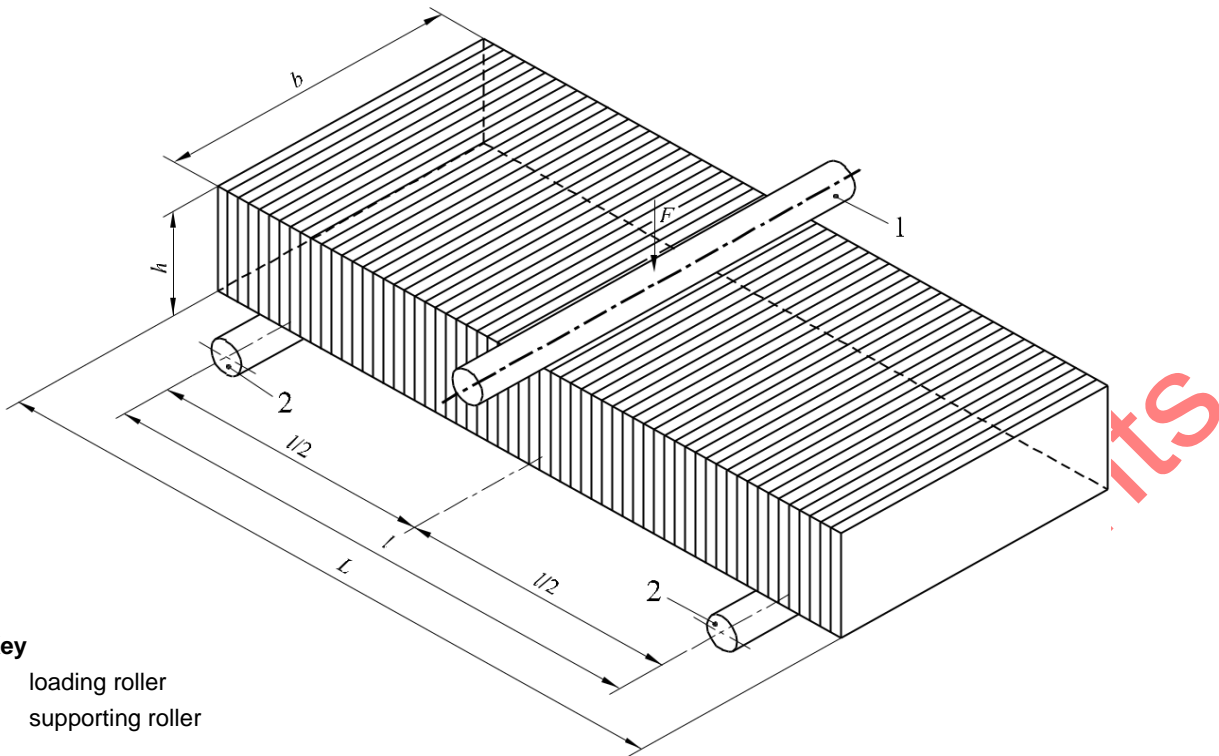

Figure B.3 — Test arrangement for a specimen with the load applied parallel to the planes of anisotropy

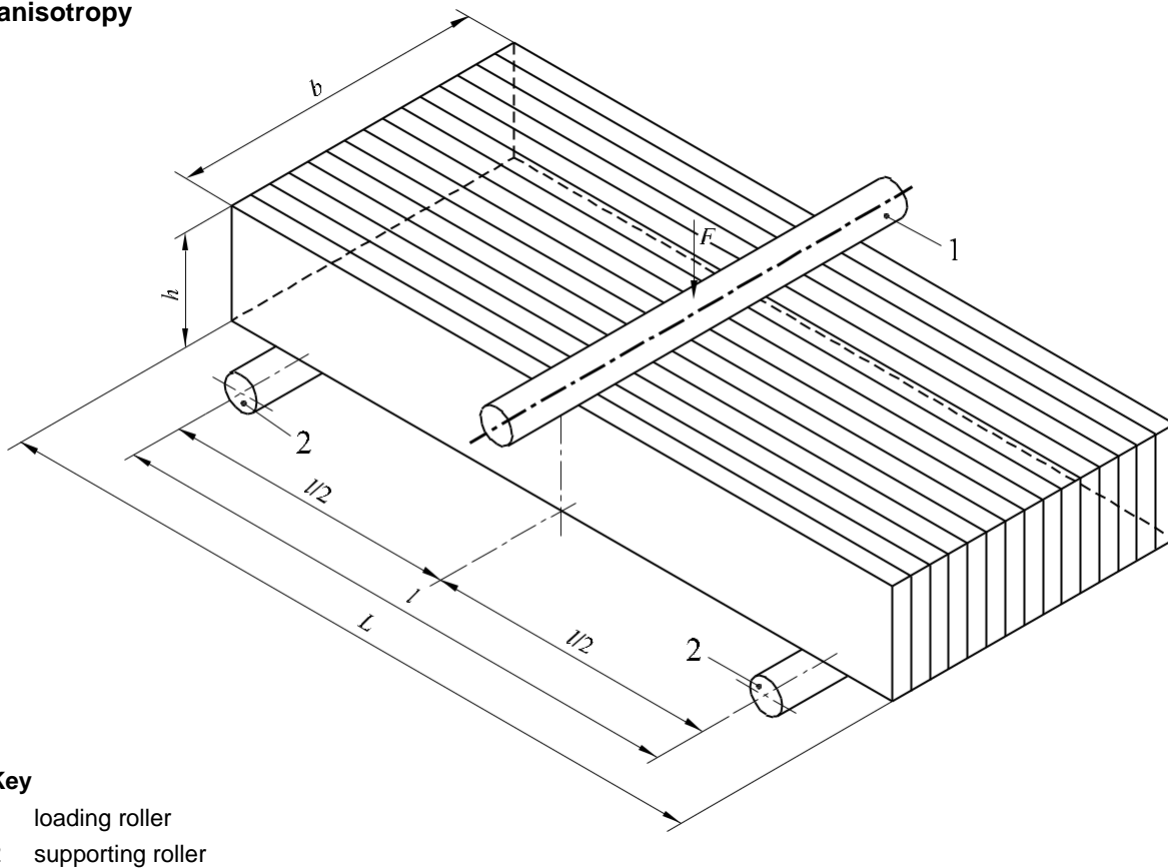

Figure B.4 — Test arrangement for a specimen with the load applied perpendicular to the edges of the planes of anisotropy

Copy for public comments

Copy for public comments

Price based on 20 pages

©RSB 2022 - All rights reserved