



**RWANDA
STANDARD**

**DRS
533**

First edition

2022-mm-dd

**Natural stone test methods —
Determination of flexural strength under
concentrated load**

ICS 73.020; 91.100.15

Reference number

DRS 533: 2023

© RSB2023

In order to match with technological development and to keep continuous progress in industries, standards are subject to periodic review. Users shall ascertain that they are in possession of the latest edition

© RSB2023

All rights reserved. Unless otherwise specified, no part of this publication may be reproduced or utilized in any form or by any means, electronic or mechanical, including photocopying and microfilm, without prior written permission from RSB.

Requests for permission to reproduce this document should be addressed to:

Rwanda Standards Board

P.O Box 7099 Kigali-Rwanda

KK 15 Rd, 49

Tel. +250 788303492

Toll Free: 3250

E-mail: info@rsb.gov.rw

Website: www.rsb.gov.rw

ePortal: www.portal.rsb.gov.rw

Contents	Page
Foreword	iv
1 Scope	1
2 Normative references	1
3 Terms and definitions	1
4 Principal	1
5 Symbols (and abbreviated terms)	1
6 Apparatus	2
7 Preparation of the specimens	2
7.1 Sampling	2
7.2 Test specimens	2
7.2.1 Surface finish	2
7.2.2 6.2.2 Dimensions	2
7.2.3 Tolerance	3
7.2.4 Planes of anisotropy	3
7.2.5 Conditioning before testing	3
8 Test procedure	3
9 Expression of the results	4
10 Test report	4
Annex A (normative) Statistical evaluation of the test results	8
A.1 Scope	8
A.2 Symbols and definitions	8
A.3 Statistical evaluation of test results	9

Foreword

Rwanda Standards are prepared by Technical Committees and approved by Rwanda Standards Board (RSB) Board of Directors in accordance with the procedures of RSB, in compliance with Annex 3 of the WTO/TBT agreement on the preparation, adoption and application of standards.

The main task of technical committees is to prepare national standards. Final Draft Rwanda Standards adopted by technical committees are ratified by members of RSB Board of Directors for publication and gazettment as Rwanda Standards.

DRS533 was prepared by Technical Committee RSB/TC 9, *Civil engineering and building materials*.

In the preparation of this standard, reference was made to the following standard:

BS EN 12372:2006, Natural stone test method — Determination of flexural strength under concentrated load

The assistance derived from the above source is hereby acknowledged with thanks.

Committee membership

The following organizations were represented on the Technical Committee on *Civil engineering and building materials* (RSB/TC 9) in the preparation of this standard.

A+Construction Group Ltd

Africeramics Ltd

Consultants Engineers Group (CEG) Ltd

D&D Resources Ltd

Dutureheza Ltd

Enabel Rwanda

Greenpack Africa Ltd

Integrated Polytechnic Regional Centre (IPRC) - Musanze

Mass Design Group

NP Construction Company (NPCC) Ltd

Road Transport Development Agency (RTDA)

Rwanda Housing Authority (RHA)

Rwanda Inspectorate, Competition and Consumer Protection Authority (RICA)

Rwanda Quarries Association (RQA)

SKAT Consult

St Joseph Engineering Company (SJEC) Ltd

Standards for Sustainability (SfS)

Stonecraft Industries Ltd

University of Rwanda - College of Science and Technology (UR - CST)

Rwanda Standards Board (RSB) – Secretariat

Copy for public comments

Copy for public comments

Natural stone test methods — Determination of flexural strength under concentrated load

1 Scope

This Draft Rwanda Standard specifies a test method for determination of flexural strength under a concentrated load for natural stone. Both an identification and a technological product testing procedure are included.

2 Normative references

The following documents are referred to in the text in such a way that some or all of their content constitutes requirements of this document. For dated references, only the edition cited applies. For undated references, the latest edition of the referenced document (including any amendments) applies.

ISO 1920 , Testing hardened concrete

3 Terms and definitions

For the purposes of this standard, the terms and definitions given in DRS 515 and ISO 1920 apply.

4 Principal

The principle of this method is to place a specimen on two rollers and to progressively load the specimen in the middle. The breaking load is measured and the flexural strength calculated.

5 Symbols (and abbreviated terms)

For the purposes of this document, the following symbols apply.

R_f flexural strength, in Megapascals

F_b breaking load, in newtons

α load rate, in Megapascals/second

V loading rate, in newtons/second

l distance between the supporting rollers, in millimetres

b width of the specimen adjacent to the plane of fracture, in millimetres

h thickness of the specimen adjacent to the plane of fracture, in millimetres

L total length of the specimen, in millimetres

6 Apparatus

5.1 A balance capable of weighing the specimen with an accuracy of 0.01 % of the mass of the specimen.

5.2 A ventilated oven capable of maintaining a temperature of (70 ± 5) °C.

5.3 A linear measuring device with an accuracy of 0.05 mm.

5.4 A testing machine of appropriate force, in accordance with the ISO 1920 and calibrated according to this European Standard.

5.5 A device for applying loads on the specimen by a centre-point load. It consists of two lower rollers (supporting rollers) and one upper roller (load-applying roller) which shall be centred exactly in the middle between the two supporting rollers (see Figure 1). The distance between the two supporting rollers shall be reported as requested in 7.2.2.

5.6 A room which can be maintained at a temperature of (20 ± 10) °C.

7 Preparation of the specimens

7.1 Sampling

The sampling is not the responsibility of the test laboratory except where specially requested. At least 10 specimens shall be selected from a homogeneous batch (see also 6.2.4).

7.2 Test specimens

7.2.1 Surface finish

As a standard reference, the surface finish of the faces of the specimens shall be sawn, honed or polished (identification test). In case of necessity to test specimens with other surface finishes (e.g. flamed, sandblasted) as required for application, this may be done (technological test). For the technological test the specimens may be final products or sawn from final products. The surface intended for use shall be in contact with the two supporting rollers (facing downwards). In any case the kind of surface finish shall be stated in the report.

7.2.2 6.2.2 Dimensions

For stones with a size of the largest grain lower than 25 mm, preferred dimensions are 50 mm × 50 mm × 300 mm.

Other dimensions are possible, but shall fulfil the following requirements:

— the thickness *h* shall be between 25 mm and 100 mm and shall be greater than twice the size of the largest grain in the stone;

- the total length L shall be equal to six times the thickness;
- the width b shall be between 50 mm and three times the thickness ($50 \text{ mm} \leq b \leq 3h$), and in no case it shall be less than the thickness.

The distance between the supporting rollers l shall be equal to five times the thickness.

7.2.3 Tolerance

The tolerance on the distance between the supporting rollers l shall be ± 1 mm.

7.2.4 Planes of anisotropy

If the stone shows planes of anisotropy (e.g. bedding, foliation) the specimens shall be prepared in accordance with at least one of the arrangements shown in Figures 2 to 4 and the direction of the planes of anisotropy shall be marked on each specimen by at least two parallel lines.

If the use of the stone in respect of the position of the planes of anisotropy is known, the test shall be carried out with the force applied on the face that will be loaded during use.

If the way of use of the stone is not known but the position of the planes of anisotropy is indicated on the specimens (by means of at least two parallel lines), the test shall be carried out on each of the three arrangements shown in Figures 2 to 4; the total number of specimens will then be 3 times 10.

7.2.5 Conditioning before testing

The specimens shall be dried at $(70 \pm 5)^\circ\text{C}$ to a constant mass.

Constant mass is reached when the difference between two weighings carried out (24 ± 2) h apart is no greater than 0.1 % of the first of the two masses.

After drying and prior to testing the specimens shall be stored at $(20 \pm 5)^\circ\text{C}$ until the thermal equilibrium is reached. After that the test shall be performed within 24 h.

8 Test procedure

Wipe the surface of the rollers clean and remove any loose grits from the faces of the specimen that will be in contact with the rollers.

The specimen is placed centrally on the supporting rollers (see Figures 1 to 4). The loading roller is placed in the middle of the specimen.

The load is increased uniformly at a rate of (0.25 ± 0.05) MPa/s until the specimen breaks.

NOTE 1 The breaking load is rounded to the nearest 10 N and also the place where the fracture occurs. The width and the thickness of the specimen are measured adjacent to the fracture plane and the dimensions are expressed in millimetres to the nearest 0.1 mm.

NOTE 2 Where the loading rate (V) is needed in N/s the following equation can be used to determine the required rate in N/s:

9 Expression of the results

The flexural strength R_{tf} of each specimen is calculated using the following equation:

The result shall be expressed in Megapascals to the nearest 0.1 MPa.

If the fracture is situated more than 15 % of the distance between the supporting rollers from the middle of the specimen and/or flaws are present (veins, fissures etc.) it shall be mentioned in the test report.

10 Test report

The test report shall contain the following information:

- a) unique identification number of the report;
- b) the number, title and date of issue of this Rwanda Standard, i.e. DRS 533
- c) the name and address of the test laboratory and the address where the test was carried out if different from the test laboratory;
- d) the name and address of the client;
- e) it is the responsibility of the client to supply the following information:
 - the petrographic name of the stone;
 - the commercial name of the stone;
 - the country and region of extraction;
 - the name of the supplier;
 - the direction of any existing plane of anisotropy (if relevant to the test) to be clearly indicated on the sample on each specimen by means of two parallel lines;
 - the name of the person or organization which carried out the sampling;
 - the surface finish of the specimens (if relevant to the test);
- f) the date of delivery of the sample or of the specimens;
- g) the date when the specimens were prepared (if relevant) and the date of testing;

- h) the number of specimens in the sample;
- i) the dimensions of the specimens;
- j) the surface finish of the specimens;
- k) the rate of loading in Megapascals per second to the nearest 0,05 MPa/s;
- l) for each specimen: the width and thickness adjacent to the fracture plane and the distance between the supporting rollers in millimetres to the nearest 0.1 mm, the orientation of the force relatively to any plane of anisotropy following Figures 2 to 4, the breaking force in newton to the nearest 10 N, the flexural strength in Megapascals to the nearest 0.1 MPa, the location of the fracture and any anomalies observed;
- m) for each relevant direction of loading the mean value R_{tf} of the flexural strength and the standard deviations, in Megapascals to the nearest 0.1 MPa;
- n) all deviations from the standard and their justification;
- o) remarks.

The test report shall contain the signature(s) and the role(s) of the responsible(s) for the testing and the date of issue of the report. It shall also state that the report shall not be partially reproduced without written consent of the test laboratory.

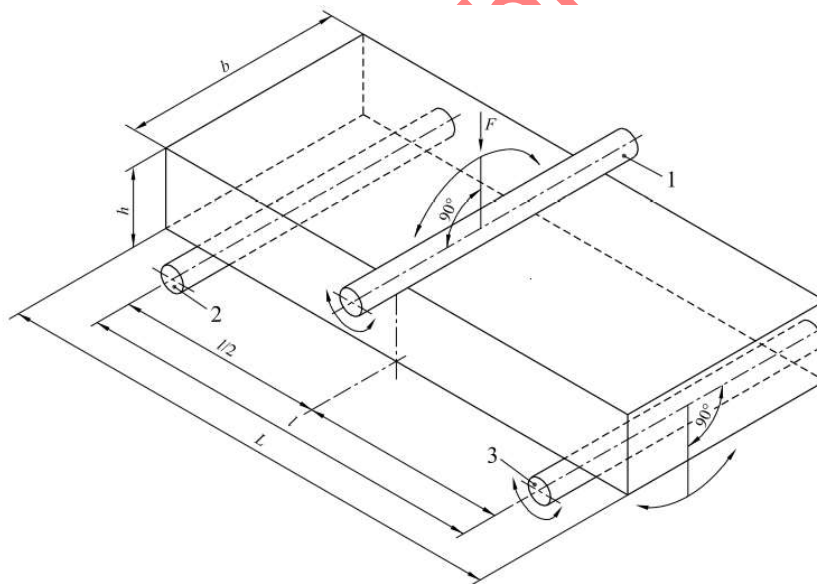

Key

- 1 loading roller
- 2 supporting roller

Figure 1 — Arrangement of loading of test specimen (centre point loading)

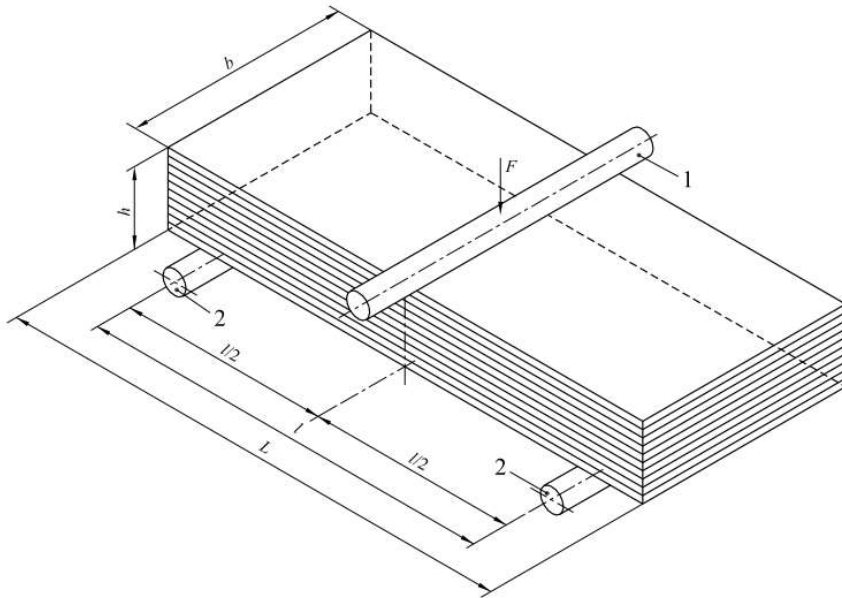

rents

Key

- 1 loading roller
- 2 supporting roller

Figure 2 — Test arrangement for a specimen with the load applied perpendicular to the planes of anisotropy

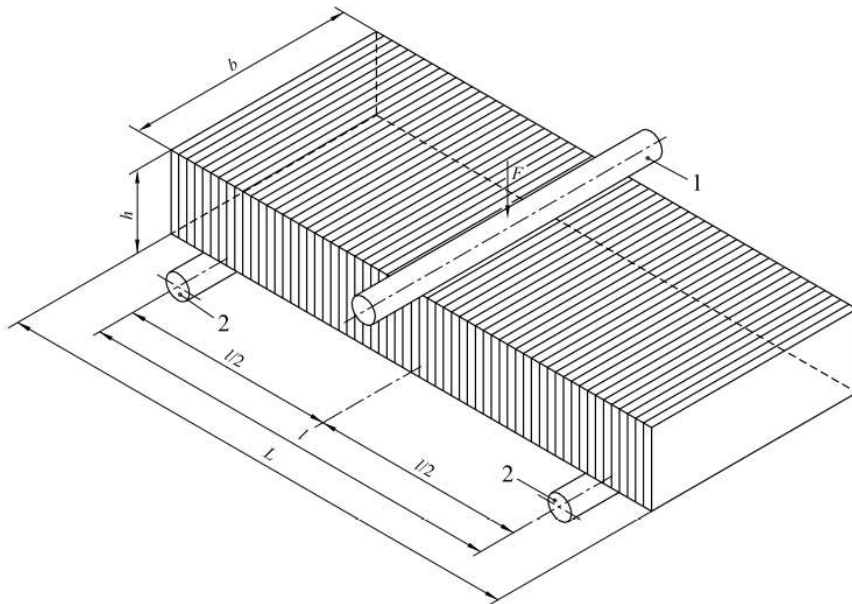

Key

- 1 loading roller
- 2 supporting roller

Figure 3 — Test arrangement for a specimen with the load applied parallel to the planes of anisotropy

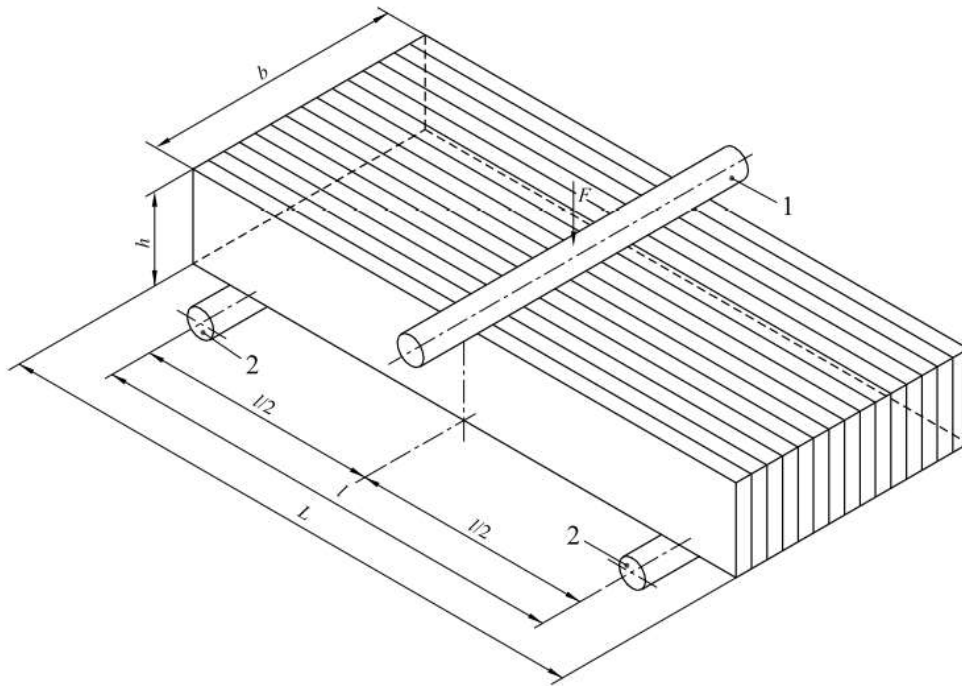

3

Key

- 1 loading roller
- 2 supporting roller

Figure 4 — Test arrangement for a specimen with the load applied perpendicular to the edges of the planes of anisotropy

Copy for pu

Annex A (normative)

Statistical evaluation of the test results

A.1 Scope

This annex establishes a method for the statistical treatment of test results obtained following the natural stone test methods described in this Rwanda Standard.

A.2 Symbols and definitions

Measured values $x_1, x_2, \dots, x_i, \dots, x_n$

Number of measured values n

Mean value $\bar{x}_1 = \frac{1}{n} \sum_i x$

Standard deviation $\bar{s}_1 = \sqrt{\frac{\sum(x_i - \bar{x})^2}{n-1}}$

Coefficient of variation $V = \frac{s}{x}$, (for individual values)

Logarithmic mean $\bar{x}_{ln} = \frac{1}{n} \sum_i \ln x_i$

Logarithmic standard deviation $\bar{s}_{ln} = \sqrt{\frac{\sum(\ln x_i - \bar{x}_{ln})^2}{n-1}}$

Maximum value Max

Minimum value Min

Lower expected value $E = e^{(\bar{x}_{ln} - (k_s * s_{ln}))}$, where k_s (quantile factor) is given in Table A.1

Quantile factor k_s see Table A.1

A.3 Statistical evaluation of test results

For the calculation of the mean value (\bar{x}), the standard deviation (s) and the coefficient of variation (v) a normal distribution is assumed.

For the calculation of the lower expected value (E) a logarithmic normal distribution is assumed. The lower expected value (E) corresponds to the 5 % quantile of a logarithmic normal distribution for a confidence level of 75 %.

Table A.1 — Quantile factor (k_s) in dependence on the number of measured values (n) in correspondence to the 5 % quantile for a confidence level of 75 %

n	k_s
3	3,15
4	2,68
5	2,46
6	2,34
7	2,34
8	2,19
9	2,14
10	2,10
15	1,99
20	1,93
30	1,87
40	1,83
50	1,81
∞	1,64

The following examples should help to clarify the method:

EXAMPLE 1 Calculation of mean value, standard deviation, maximum value and minimum value of 6 measured values:

Measurement no	Measured value x
1	2 000
2	2 150
3	2 200
4	2 300
5	2 350
6	2 400

Mean value	2 333
Standard deviation	147
Maximum value	2 400
Minimum value	2 000

EXAMPLE 2 Calculation of mean value, standard deviation, coefficient of variation and lower expected value of 10 measured values:

Measurement no	Measured value x	(ln x)
1	2 000	(7,60)
2	2 150	(7,67)

Copy for public comments

Price based on 10pages

©RSB 2022- All rights reserved